

Multistage Pressure Control Pumps

trevoli

TREVOLI Models: CMB-SP3-37, CMB-SP3-47, CMB-SP5-37, CMB-SP5-47, CMB 3-56, CMB 5-57, CMB 5-67

Instruction manual

1. General Information

Thank you for purchasing a Trevoli Water Pump. These instructions are designed to ensure the correct installation and best use of the Trevoli CMB Multistage pressure pump. Trevoli CMB water pumps are quiet, efficient & designed to provide an automatic supply of clean water to your household or application.

Please note, If the water consumption is greater than 3 L/min the pump will operate continuously. To combat this, we would recommend a Trevoli pressure tank, available in sizes 3-300L.

Trevoli CMB pumps are plug and play and sold with an automatic controller, they come wired with a NZ approved 3-pin plug. If any wiring is altered, we would recommend paying strict attention to correct wiring diagrams and employing an electrician. This will avoid the possibility of overloading the control circuit or of any other problems associated, for which we can accept no responsibility.

The pump will operate on and off when a tap is opened and closed. It will cut in at either 1.5 Bar (37) or 2.2 Bar (47, 56, 57, 67). When the pump reaches maximum pressure, the unit automatically switches the pump off. Unit selection must take into account that the differential must be over 140 kPa.

Trevoli Pumps are not intended for use by young children or infirm persons without supervision. Young children should be supervised to ensure they do not play with the pump.

2. Installation

Trevoli CMB pumps are self-priming (once primed initially) & have an 6m suction lift which makes them suited to below ground tanks as well as gravity fed applications.

The Pump should be protected from the risk of flooding and other elemental effects by being installed in a sheltered but well-ventilated place. Being installed on a solid base will also keep the pump from moving and creating noise.

If the pump and automatic controller is directly connected to mains water supply, it must be noted that the incoming pressure will be added to that provided by the pump. Total pressure must not exceed 6 bar. It can be fitted to any installation that has sufficient water supply.

3. Suction pipe work assembly

The suction pipe should be a minimum diameter of 25mm, maximum diameter of 32mm. If a suction lift is required as per fig 4, a foot valve is recommended on the end of the suction line. Suction lengths greater than 10m in distance require a non-return valve to be fitted at the pump inlet.

4. Discharge pipework assembly

The discharge (outlet) pipework diameter should be equal to or larger than that of the pump discharge. The discharge pipe should not be supported by the pressure unit and should be checked for water tightness. We recommend the use of a flexible anti vibration hose on the discharge as direct connection to rigid pipework can transmit sound.

5. Electrical connection

The nominal pump current should be no higher than 10 A and the maximum motor power (P1) should never exceed 1.8 kW. Ensure that all the connections between the electronic circuit and the power and motor cables are properly made. Protection of the system should include a 30mA RCD residual current device. The supply cable should comply with EEC standards (2) or be of type H07 RN-F as per VIDE 0620.

6. Controls prior to start-up

Before starting the pump ensure the Pump wet end and intake pipework are fully primed with all air removed and air tight. Check that the grid voltage and frequency match those featured on the specification plate. Check that the pump shaft turns freely.
THE PUMP SHOULD NEVER BE OPERATED DRY

7. Start-up

Open all valves in the intake and discharge lines.

Switch on the power and the pump will start automatically. While doing so, leave the discharge tap open to bleed any air that may be in the system. Once air has been bled, close the tap and the pump will turn off when it reaches maximum pump pressure. Verify the motor is rotating clockwise which can be checked from by looking through the fan cover.

If the pump is not properly primed or there is no water supply, it will shut down after 30 seconds & the controller will activate failure mode. Once the water level is recovered and the pump has been properly primed, repeat the start-up operation, this time holding in the red reset button for a few seconds. If the pump does not operate, does not produce pressure or does not shut down, try to work out the cause of the problem by consulting the troubleshooting guide provided.

8. Maintenance

Trevoli CMB multistage pressure pumps require no specific maintenance. We recommend that these pumps are emptied when temperatures are low and if there is a risk of freezing. If the unit is not used for a long period of time, it is recommended that it be emptied of water, as PH level can alter over time. Store in a dry, well ventilated place.

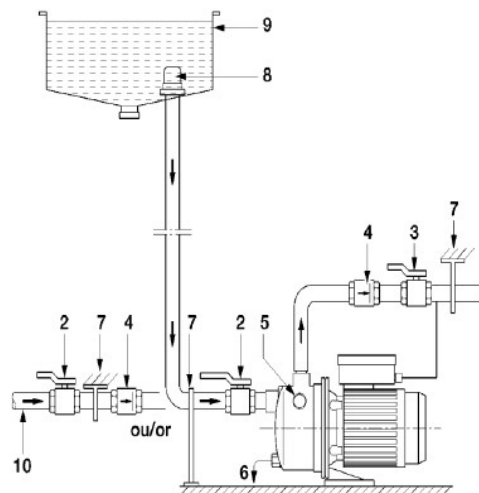
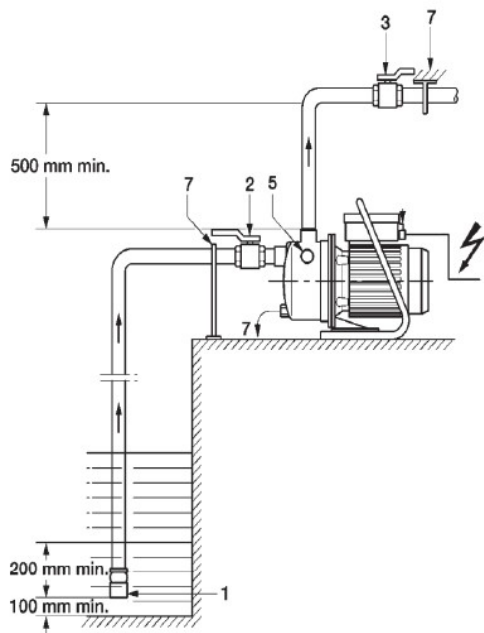

Legend for Installation samples

- Pos. 1 Strainer-foot valve (maximum passing section 1 mm)
- Pos. 2 Pump suction valve
- Pos. 3 Pump discharge valve
- Pos. 4 Non-return valve
- Pos. 5 Filling plug
- Pos. 6 Draining plug
- Pos. 7 Pipe supports
- Pos. 8 Strainer
- Pos. 9 Storage tank
- Pos. 10 Town water supply

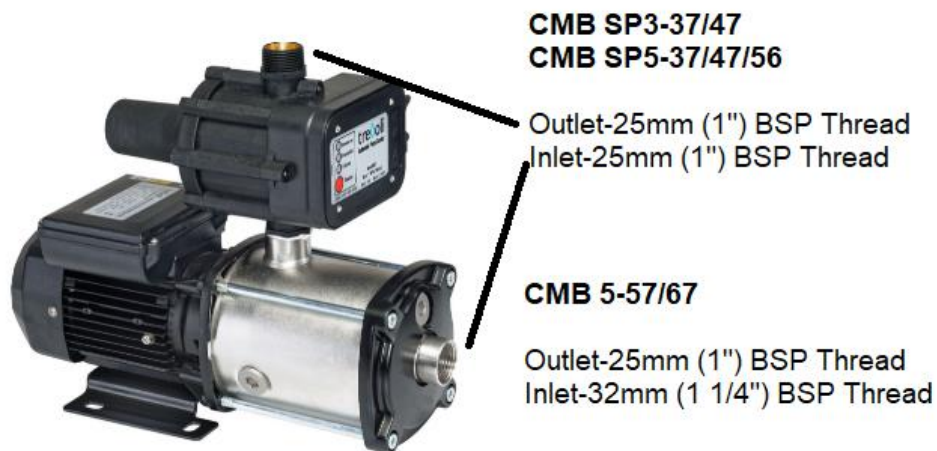

CMB SP3-37/47
CMB SP5-37/47/56



Outlet-25mm (1") BSP Thread
 Inlet-25mm (1") BSP Thread

CMB 5-57/67

Outlet-25mm (1") BSP Thread
 Inlet-32mm (1 1/4") BSP Thread

Use thread tape on your connections

Trouble-Shooting Guide

Faults, Causes and Remedies		
Faults	Causes	Remedies
Pump does not run	Interruption of the current, short circuit insulation fault in the motor coil	Check power supply, call a qualified electrician to check cable and motor
	Pump is blocked with foreign matter	Switch off the pump voltage and secure against re-operation, close the shut of fittings at the back and front of the pump, remove the foreign from the pump
	Protective motor switch activated	Let the pump/motor cool
Motor overheats	Too low voltage	Check the voltage on terminals of the motor it should be within +/- 10% (50Hz) of the rated voltage
	Pump is blocked with foreign matter	see above
	Ambient temperature above 45deg	Operate at below 45 degrees
	Altitude above 1000m	Operate below altitude of 1000m
Thermal relay	Voltage is too low	Check the adequate cross section of the electrical cable conductors
	A phase is cut	Check and change the electrical cable if necessary
	Thermal relay of the circuit-breaker is defective	Replace it
	Motor is defective	Replace it
Pump runs but delivers little or no water	Pump is blocked with foreign matter	see above
	Pump is empty	Fill the pump
	Suction pipe is obstructed	Clean all the pipes
	Air in the suction pipes	Check tightness of the whole pipe up to the pump
Pump vibrates	loose on foundations	Check and completely tighten the nuts of the stud bolts
	Pump is blocked with foreign matter	see above
	Bad electrical connection	Check the connections to the pump
	Disposal: do not dispose of electrical appliance as unsorted municipal waste, use separate facilities	
		





WARRANTY TERMS & CONDITIONS

(Subject to the provisions of the Consumers Guarantee Act)

1) Vortex Distributors warrants that the TREVOLI pumps that we distribute are free from defects in workmanship and materials, for 2 YEARS from the date of purchase. Subject to the conditions of the warranty Vortex Distributors will repair any defective products free of charge at the premises of our authorized service agents throughout New Zealand.

2) This warranty is back to base & excludes transportation costs to and from Vortex Distributors or its appointed service agents and excludes defects due to non-compliance with installation instructions, neglect or misuse, inadequate protection against freezing, low voltage or use or operation for purposes other than those for which they were designed. For further information regarding the suitability of your intended application contact us.

3) The 2 YEAR warranty refers only to TREVOLI pumps sold after the 1st July 2006, and is not transferable to another TREVOLI pump and only applies to the original owner, purchaser or end user, and is subject to the Consumers Guarantee Act.

4) Our warranty commences from the date of purchase of the above-mentioned pumps. Proof of purchase is required before consideration under warranty is given. Record your date of purchase in the space below and retain this copy for your records.

Date of Purchase:

Model Purchased:

Invoice #:



Vortex Distributors

2D Rothwell Avenue, Rosedale, Auckland 0632

Ph: 0800 102 335