

Trevoli Pressure Tank Limited Warranty

Vortex Distributors warrants its Trevoli Pressure Tank Series tanks against manufacturing defects in material and workmanship for a period of 5 years from the date of purchase. Warranty applies to Trevoli products only when used for their intended purpose and does not apply if a defect is due to improper use of the product, result of accident, misuse or abuse. If the product was improperly installed or altered in any way, not specifically authorised by us, the warranty is void. The warranty set forth in this paragraph is made expressly in lieu of all other warranties expressed, or implied including but not limited to merchantability or fitness for a particular purpose.

In no event shall Vortex Distributors be liable for cost of processing, lost profits, goodwill or any other consequential or incidental damage of any kind resulting from the order or use of its products whether arriving from breach of warranty, nonconformity to ordered specifications, delay in delivery, or any loss sustained by the buyer, nor will Vortex Distributors be liable for labour and expenses necessary to remove and reinstall replacement products. To obtain service under this warranty, the consumer must deliver alleged defective product, freight prepaid to an authorised Trevoli Products distributor. Vortex Distributors will either issue a credit or at its option, repair or replace the defective product freight prepaid to the distributor.

All warranty is subject to verifiable proper installation, adjustment of precharge as per our product instructions and installation of a pressure relief valve as recommended in the installation manual.

INSTALLATION AND OPERATING MANUAL

TREVOLI - Pressure Tank Series

CAUTIONS AND WARNINGS

⚠ **CAUTION:** To prevent personal injury, ensure all water pressure is released from the pressure system prior to work being performed. Ensure pumps are disconnected and / or electrically isolated.

⚠ **WARNING:** It is strongly recommended that the system is protected by a suitable pressure relief valve set at or below the maximum tank pressure rating. Failure to install a relief valve may result in tank explosion in the event of a system malfunction or over pressurization, resulting in property damage, serious personal injury or death.

⚠ **WARNING:** If the pressure tank leaks or shows signs of corrosion or damage do not use it.

1. Well Water and Booster System Tank Installation

1.1 Proper Pressure Tank Location

In order to ensure your tank provides its maximum service life it should always be installed in a covered, dry position. The tank should not be allowed to rub against any surrounding hard surfaces, such as walls etc.

Install the tank at a suitable location to prevent water damage due to leaks. The tank should always be located downstream from the pump. If the tank is located at a lower elevation than the demand then a check valve should be installed. If the tank is installed remotely from the pump then install the pressure switch near the tank. The tank should be installed as close as possible to the pressure switch, transducer or flow sensor. This will reduce the adverse effects of added friction loss and differences in elevation between the tank and / or the water mains' and the pressure switch, transducer or sensor.

1.2 System Connection

1. Place the pressure tank in its final desired location.
2. Level as necessary. All vertical and horizontal model tanks should be placed on a firm base. If vibration is likely to occur in the vicinity the tank should be mounted on a resilient mounting. Tanks with steel bases should be mounted using "L" brackets, while tanks with plastic bases should be mounted through the holes in the base. For bases without holes, holes should be drilled at four points equally distant along the rim of the base and then mounted accordingly. Inline tanks should be connected directly to the pump or to the supply line using a "T" connection.
3. Connect the tank to the pump supply line with a short pipe to eliminate unnecessary friction loss.
4. All piping should be in accordance with prevailing local codes and standards.
5. Tanks mounted on booster sets should be strapped down for shipment.

1.3 Adjusting Precharge Pressure

Correct precharge is required for proper tank performance.

1. For tanks installed with a pressure switch controlled pump with a differential pressure set up to 2 bar (30 psi), the precharge should be set to 0.2 bar (2 psi) below the cut-in pressure.
2. For tanks installed with a pump controlled by a pressure switch with a pressure differential greater than 2 bar (30 psi), electronic controls or variable speed controls, the precharge should be set to 65% of the cut-out or maximum system pressure.
3. For tanks installed on mains' pressure, the tank precharge should be set equal to the mains' pressure. For mains' pressure

Installed on _____ by _____

PLEASE READ ALL INSTRUCTIONS BEFORE INSTALLING YOUR PRESSURE TANK

These instructions have been prepared to acquaint you with the correct method of installing and operating your Trevoli pressure tank. We urge you to study this document carefully and follow all of the recommendations. In the event of installation difficulties or the need for further advice, you should contact the dealer from whom you purchased the system or the nearest Trevoli sales office.

- The Trevoli Pressure Tank Series tanks are designed for use in well water or potable water booster systems. Refer to Section 1 for installation details.
- See tank data label for maximum working pressure and maximum temperature.
- Be sure to protect tank, piping and all system components from freezing temperatures.
- The manufacturer is not responsible for any water damage in connection with this diaphragm pressure tank.

INSTALLATION MUST BE IN ACCORDANCE WITH LOCAL PLUMBING CODES.

exceeding 6 bar (88 psi), a suitable pressure regulator should be installed.

- This is a diaphragm type pressure tank for use on a well water or booster system. The system must be protected by a suitable relief valve.

For correct operation, pressure tanks should be precharged as follows:

- Turn off the pump, disconnect the tank from the system and completely drain all water inside the tank to avoid water pressure affecting precharge readings.
- Using a suitable pressure gauge, check the precharge pressure of the tank.
- Release or add air as necessary to adjust to the required precharge pressure.
- Replace protective air valve cap and seal with the air valve label, if provided. This will enable you to determine if the valve has been tampered with in case of future service calls.
- After correctly setting the precharge, no regular air charge checks are required.

Do not check air after installation.

CAUTION: Never over-charge the tank and precharge the tank with air at ambient temperature only!

If the tank is to be precharged over 4 bar (58 psi):

- Adjust the precharge of the tank to 4 bar (58 psi).
- Install the tank into the system.
- Fill the system with water to equalise the system and precharge pressure at 4 bar (58 psi).
- Increase precharge pressure in maximum 3 bar (44 psi) steps and afterwards adjust the system pressure to the new precharge pressure by filling water into the system.
- Repeat steps 3 and 4 until the required precharge is reached.

Emptying a tank that has a precharge over 4 bar (58 psi):

- Make sure there is some water in the tank.
- Isolate the tank from the system (close isolation valve).
- Make sure no additional water can get into the tank (shut off the pump and / or any water supply).
- Release air from tank until 3 bar (44 psi) tank / air pressure is remaining.
- Open a drain valve and afterwards the isolation valve to drain the tank.

CAUTION: Make sure that the system pressure is never lower than 4 bar (58 psi) below precharge. If system pressure needs to be lowered, the tank should be isolated or emptied as previously described.

1.4 Typical Installations

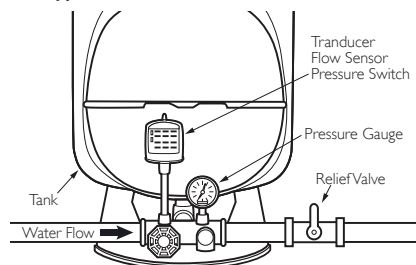

Fig. 1.4-1 Tank Installation with Accessories

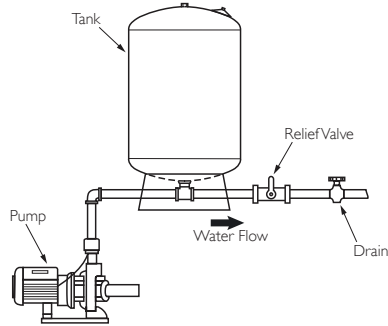

Fig. 1.4-2 With Convertible Jet Pump

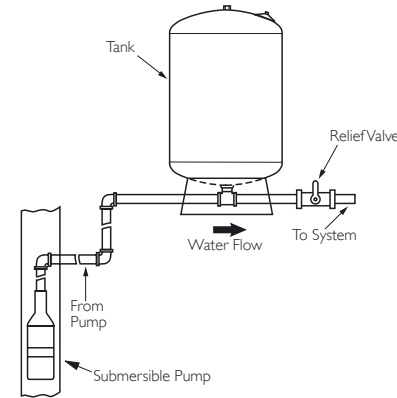

Fig. 1.4-3 With Submersible Pump

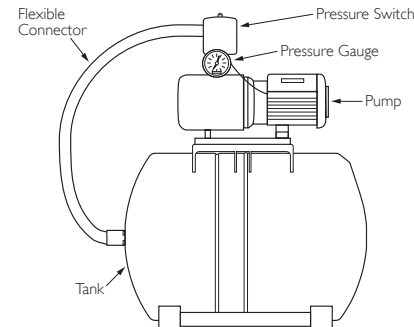

Fig. 1.4-4 Booster Pump w/ Horizontal Tank

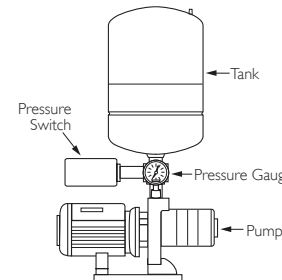

Fig. 1.4-5 Booster Pump w/ Inline Tank

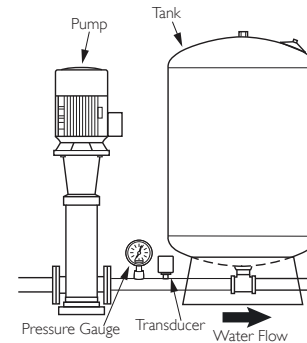

Fig. 1.4-6 Booster Pump w/ Tank

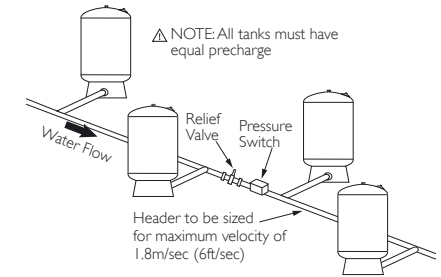

Fig. 1.5 Multi-tank Installation

1.6 Pump Run Control Operating Principles

Without a pressure tank, a water system's pump would cycle (turn on) every time there was a demand for water. This frequent and potentially short cycling would shorten the life of the pump. Pressure tanks are designed to store water when the pump is running and then deliver pressurized water back to the system when the pump is shut off (Fig 1.6). A properly sized tank will store at least one liter of water for every liter per minute (LPM) of pump capacity. This allows for fewer pump starts and longer run times which should maximize the life of the pump.

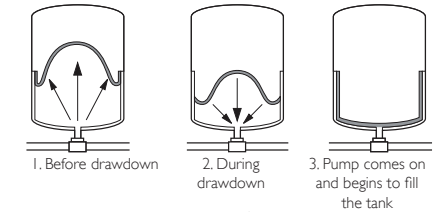

Fig. 1.6

2. Disposal

Check with local authorities for proper disposal and recycling.



1.5 Multiple Tank Installation

All tanks must have the same precharge for the system to function properly. Tanks should be installed on a header to ensure all tanks receive equal and balanced pressure. Adjust each tank precharge as detailed in section 1.3. The system pressure switch or control should be centrally located (see Fig 1.5) in order for the tanks to function properly.